

錐套式時規皮帶輪 L型
 KEYLESS TIMING PULLEYS <L>

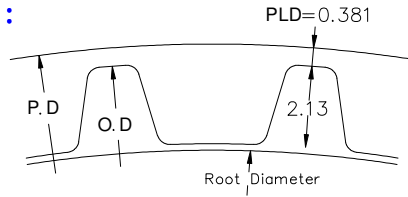

齒型圖：



皮帶輪形狀： E

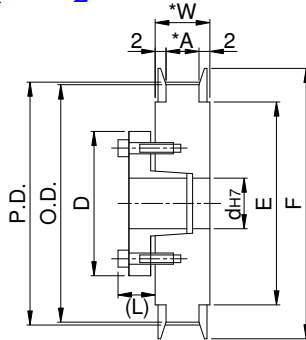

F

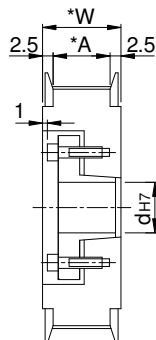

TYPE	材質	表面處理	齒圈材質	齒圈處理	錐套材質	錐套處理
KLAA	A6061	陽極	S45C	鍍鋅	S45C	染黑
KLAAA	A6061		AL	陽極		染黑
KLAH	A6061	硬陽	S45C	鍍鋅		染黑
KLAHA	A6061		AL	硬陽		染黑
KLAD	A6061	黑色陽極	S45C	鍍鋅		染黑
KLADA	A6061		AL	黑色陽極		染黑
KLSD	S45C	染黑	S45C	染黑		染黑
KLSZ	S45C	鍍鋅	S45C	鍍鋅		鍍鋅
KLSN	S45C	鍍鎳	S45C	鍍鎳		鍍鎳
KLSC	S45C	鍍鉻	S45C	鍍鉻		鍍鉻
KLSH	S45C	無電鍍線	S45C	無電鍍線	無電鍍線	
KLSS	SUS303	電解	AL	陽極	SUS303	電解

Type	Catalog No.			軸孔徑dh7	P.D	O.D	F	E
	齒數	型式.寬度	皮帶輪形狀					
KLAA KLAAA KLAH KLAHA KLAD KLADA KLSD KLSZ KLSN KLSC KLSH KLSS	14	L015 A:15 W:20	E	8~12	42.45	41.68	48	35
	15			8~12	45.48	44.72		
	16			10~17	48.51	47.75	55	40
	17			10~17	51.54	50.78		
	18			10~17	54.57	53.81		
	19	L022 A:22 W:27		12~17	57.61	56.84	67	50
	20			12~17	60.64	59.88		
	21	12~25		63.67	62.91	70	56	
	22	12~25		66.7	65.94			
	24	L027 A:27 W:32		12~30	72.77	72	80	60
25	12~32		75.8	75.04				
26	12~32	78.83	78.07	87	67			
28	12~35	84.89	84.13					
30	L040 A:40 W:45	12~42	90.96	90.2	99	80		
32		12~42	97.02	96.26				
34		12~42	103.08	102.32	104	84		
36		12~42	109.15	108.39				
38		12~42	115.21	114.45	111	90		
40	12~42	121.28	120.51					
					123	102		
					127	105		
					131	110		

Order TYPE — Catalog No. — 軸孔內徑&加工
 訂貨代號 KLAA — 36L015E — 15

註1：如需規格表以外特殊加工，請來電告知。

註2：錐套尺寸請對照錐套尺寸表。



襯套尺寸表

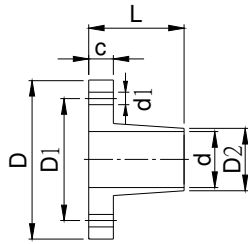

3 pcs tight fixed type
d dimension is 10~12

4 pcs tight fixed type
d dimension is 8,14~25

6 pcs tight fixed type
d dimension is 28~50

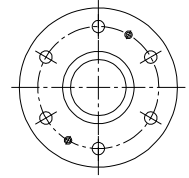
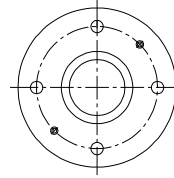
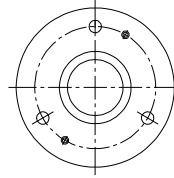

Material: S45C

軸孔徑 d	使用螺栓		拆卸用 攻牙孔	最大容許扭矩 N · m { kgf · m }	容許推力荷 重kN { kgf }	螺栓緊固扭矩 N · m { kgf · m }	D	D1	D2	d1	L	1
	支數	尺寸										
8	4	M3x12	M3x2	16 { 1.6 }	4.0 { 408 }	2.0 { 0.21 }	25.5	19	10	3.3	15.5	4
10	3	M4x16	M4x2	39 { 4.0 }	5.34 { 545 }	4.0 { 0.41 }	30	22	12	4.5	16.5	5
11				43 { 4.4 }			31	23	13			
12				48 { 4.9 }			32	24	14			
14				73 { 7.4 }			35	27	16.6			
15	4	M4x18	M5x2	78 { 7.95 }	8.74 { 895 }	8.3 { 0.85 }	36	28	17.6	5.5	22	6
16				83 { 8.5 }			37	29	18.6			
17				88 { 9.0 }			38	30	19.6			
18				154 { 15.7 }			43	33	20.6			
19	6	M5x20	M5x2	163 { 16.6 }	12.3 { 1260 }	13.7 { 1.4 }	45	35	22.4	6.6	23	7
20				171 { 17.4 }			46	36	23.4			
22				186 { 19.16 }			48	38	24.6			
24				206 { 21.0 }			50	40	26.6			
25	6	M5x25	M6x2	216 { 21.8 }	22.7 { 2320 }	34.3 { 3.5 }	52	42	28.4	8.8	24	8
28				353 { 36.0 }			54	44	30.6			
30				382 { 39.0 }			57	47	33.4			
32				412 { 42.0 }			59	49	34.7			
35	6	M6x28	M8x2	451 { 46.0 }	22.7 { 2320 }	34.3 { 3.5 }	63	53	38.4	8.8	25	9
38				686 { 70.0 }			70	58	42			
40				725 { 74.0 }			71	59	43.5			
42				757 { 77.2 }			74	62	46			
45	6	M8x35	M8x2	1490 { 152.0 }	22.7 { 2320 }	34.3 { 3.5 }	84	69	49.5	8.8	31.5	11
48				1600 { 163.0 }			87	72	52.5			
42				757 { 77.2 }			74	62	46			
45				1490 { 152.0 }			84	69	49.5			
50	6	M8x35	M8x2	1600 { 163.0 }	22.7 { 2320 }	34.3 { 3.5 }	87	72	52.5	8.8	38.5	13
50				1660 { 169.0 }			89	74	54.5			

▲錐套式時規皮帶輪的優點

不需對軸心進行鍵槽加工，但軸心的強度並不會降低。
解決標準皮帶輪鍵槽不同步的問題。
無間隙。

▲如何安裝

- 1 擦拭軸心表面和皮帶輪與錐套的接觸面並塗上薄薄一層的潤滑油。(勿使用含鉛系減低摩擦系數的潤滑油)
- 2 螺絲牙面與錐套面也請擦拭。
- 3 先組裝皮帶輪和錐套再插入軸心，未插入軸心時請勿鎖緊。
- 4 組裝位置決定後以對角線位置將螺絲輕輕鎖緊。
- 5 提高鎖緊扭力依對角次序鎖緊。
- 6 將螺絲以順時針方向全部鎖緊。

▲注意

未插入軸心時請勿將錐套鎖緊，會導致錐套變形。
請勿使用附屬螺絲以外的螺絲緊固。

▲如何拆卸

請在完全靜止狀態下依逆時針方向放鬆。
在拆卸用螺孔內鎖入螺絲並均等鎖緊至錐套退出。